

Technical Data of Oil-immersed Transformer Hermetically Sealed Type	
Model (ordering code)	: OTCO35-22K-1500K-A
Reference standard	: IEC 60076 , TIS 384-2543
Ratings	
Rated power	: 1500 (kVA)
Number of phases	: 3 (Ø)
Rated frequency	: 50 (Hz)
Rated primary voltage (± 2x2.5%)	: 22000 (V)
Rated secondary voltage	: 400 / 230 (V)
Rated primary current	: 39.37 (A)
Rated secondary current	: 2165 (A)
Insulation class	: A (105) (°C)
Connection symbol	: Dyn11
Service conditions and installation	
Ambient temperature	: 40 (°C)
Altitude (above sea level)	: ≤ 1000 (m)
Type of cooling	: ONAN
Installation method	: Outdoor
Performance of transformer at 75°C	
No load loss	: 2000 (W)
Load loss	: 18900 (W)
Short-circuit impedance	: 6.0 (%)
Efficiency at 50% of rated power (P.F.= 1.0)	: 99.11 (%)
Efficiency at 100% of rated power (P.F.= 1.0)	: 98.63 (%)
Voltage regulation at full load (P.F.= 1.0)	: 1.43 (%)
Sound level	: 60 (dB(A))
Max. Temperature rise of top oil at full load	: 60 (K)
Max. Temperature rise of winding at full load	: 65 (K)
Type of HV & LV windings conductor	: Copper
Type of insulating liquid and cooling liquid	: Mineral oil
Routine tests	
Measurement of insulation resistance	
Measurement of winding resistance (IEC 60076-1)	
Measurement of voltage ratio and check of phase displacement (IEC 60076-1)	
Measurement of no-load loss and no-load current (IEC 60076-1)	
Measurement of load loss (IEC 60076-1)	
Measurement of short-circuit impedance (IEC 60076-1)	
Induced overvoltage withstand test (IEC 60076-1) and (IEC 60076-3)	
Applied voltage test (IEC 60076-1) and (IEC 60076-3)	
Oil dielectric Breakdown voltage test (IEC 60156)	
Physical leakage test (with overpressure 5 psi)	
Type tests	
Partial Discharge (PD) test (IEC 60076-3)	
Lightning impulse (LI) test (IEC 60076-3)	
Temperature-rise test (IEC 60076-2)	

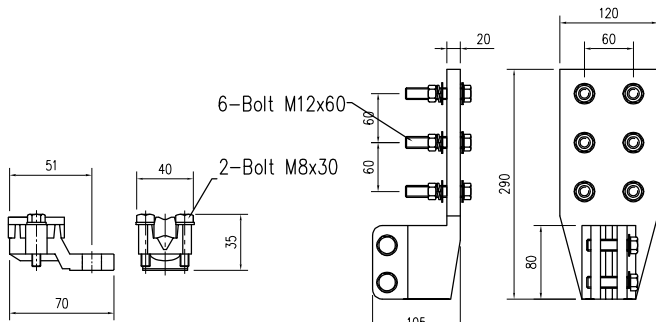

High voltage terminal

Low voltage terminal

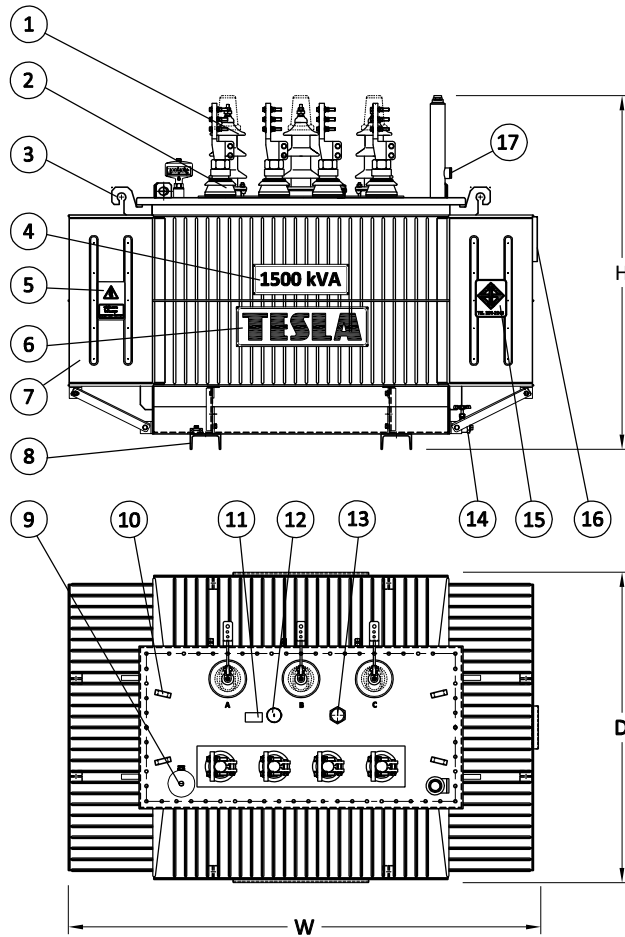
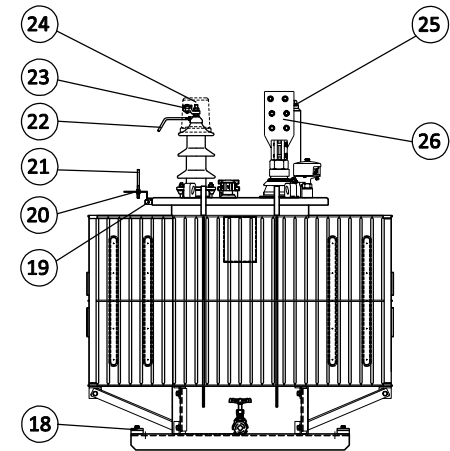

No.	Description	No.	Description
1	High voltage bushing	14	Oil drain valve
2	Low voltage bushing	15	TIS. 384-2543 sign
3	Lifting lugs	16	Nameplate
4	Capacity sign	17	Oil level gauge
5	Danger high voltage sign	18	Earthing terminal
6	Trade mark sign	19	Earthing terminal for surge arrester
7	Corrugated radiators	20	Bracket for surge arrester
8	Foundations of transformer	21	Earthing terminal for arcing horn
9	Thermometer with dual contacts	22	Arcing horn
10	Lifting eyes	23	High voltage terminal (see details)
11	Instruction for tap changer	24	Bird guard cap
12	Off-load tap changer	25	Oil filling plug
13	Pressure relief device	26	Low voltage terminal (see details)

Approximate overall dimensions, oil quantity and weight				
W (mm)	D (mm)	H (mm)	Oil quantity (Litre)	Total weight (kg)
1930	1270	1460	625	3140

TESLA

TESLA POWER CO.,LTD.

Tel. : (66) 0-2420-9065

Fax. : (66) 0-2431-0256

Website : www.teslapower.co.th

Email. : info@teslapower.co.th

